



SUNDOR 5000 SLIDING GLASS DOOR "Small MISSILE IMPACT"

GENERAL NOTES

1. This product has been evaluated and is in compliance with the 2010 Florida Building Code (FBC) structural requirements excluding the "High Velocity Hurricane Zone".
2. Product anchors shall be as listed and spaced as shown on details. Anchor embedment to base material shall be beyond wall dressing or stucco.
3. When installed greater than 30 feet above grade in areas requiring wind borne debris protection this product complies with Section 1609.1.2 of the 2010 FBC and does not require an impact resistant covering. This product meets missile level "A" and includes Wind Zone 4 as defined in ASTM E 1996 and Section 1609.1.2.4 of the FBC.
4. When installed 30 feet or less above grade in areas requiring wind borne debris protection this product must be protected with an impact resistant covering that complies with section 1609.1.2 of the 2010 FBC.
5. Site conditions that deviate from the details of this drawing require further engineering analysis by a licensed engineer or registered architect.

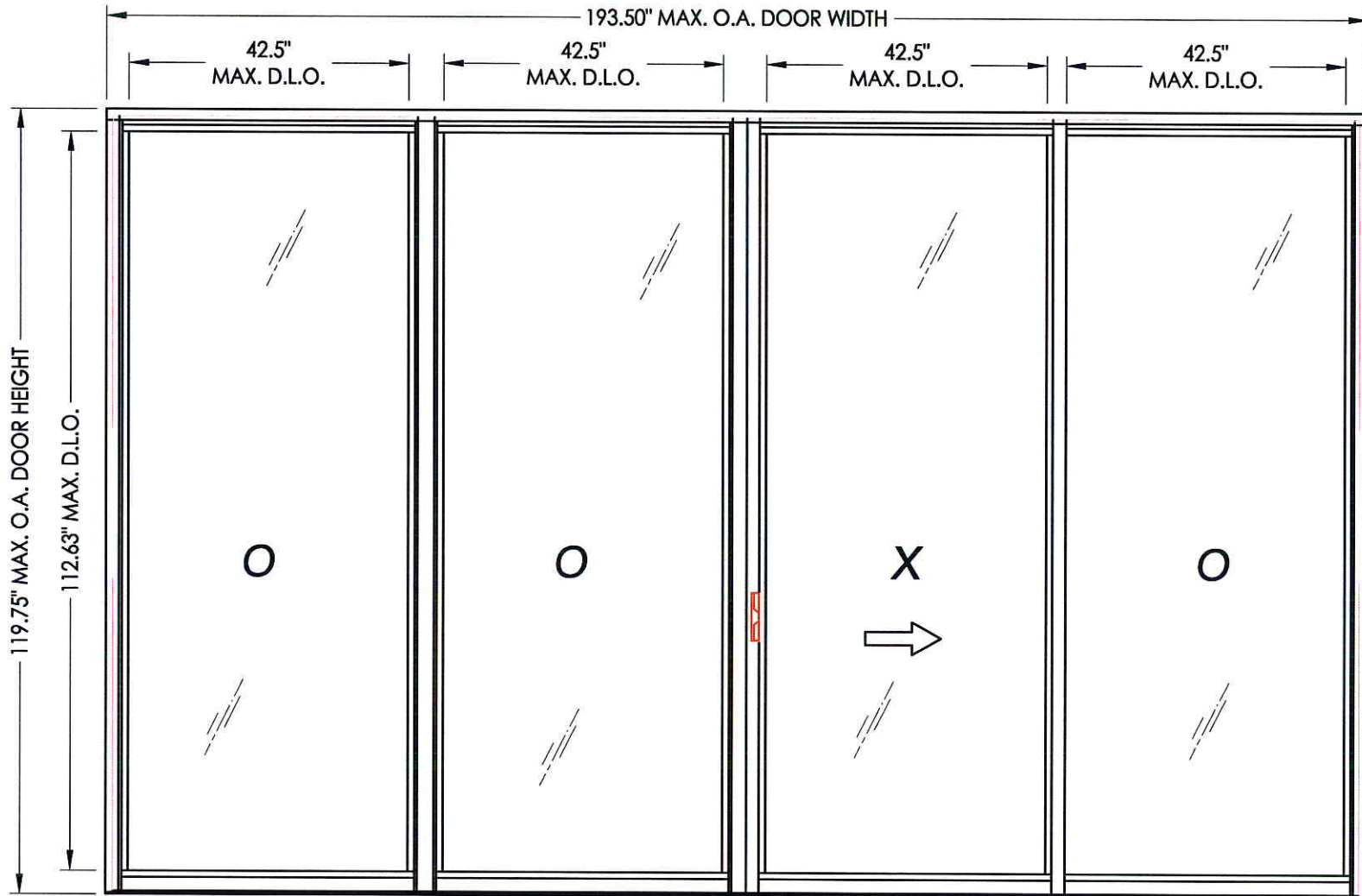

TABLE OF CONTENTS	
SHEET #	DESCRIPTION
1	TYPICAL ELEVATIONS, DESIGN PRESSURES & GENERAL NOTES
2	DOOR PANEL SECTIONS
3	DOOR PANEL SECTIONS
4	SIDELITE PANEL SECTIONS
5	CORNER DETAILS
6	HORIZONTAL CROSS SECTIONS
7	HORIZONTAL CROSS SECTIONS
8	VERTICAL CROSS SECTIONS
9	ANCHORING - CONCRETE SUBSTRATE
10	ANCHORING - STEEL SUBSTRATE
11	COMPONENTS
12	BILL OF MATERIALS & COMPONENTS

O.A. FRAME DIMENSION	D.L.O. DIMENSION	REINFORCED	GLASS TYPE	DESIGN PRESSURE (PSF)	
				POSITIVE	NEGATIVE
193.50"	42.50"	YES	G3, G4	100.0	100.0
x 119.75"	x 112.63"		G1, G2	70.0	75.0
193.50"	42.50"	NO	G1, G2	70.0	75.0
x 119.75"	x 112.63"		G3, G4		

Documents Prepared By:
RW BUILDING CONSULTANTS, INC.
 P.O. Box 230 Valrico FL 33595
 Phone No.: 813.659.9197
 Florida Board of Professional Engineers
 Certificate of Authorization No. 9813
RF 8.27.12
 Lyndon F. Schmidt, P.E. No. 43409

PRODUCT: SLIDING GLASS DOOR
 PART OR ASSEMBLY: TYPICAL ELEVATION, DESIGN PRESSURES & GENERAL NOTES

NO.	DATE	BY	REVISIONS

DATE: 8/24/12
 SCALE: N.T.S.
 DWG. BY: JK
 CHK. BY: LFS
 DRAWING NO.: FL-15903.20
 SHEET 1 OF 12

R:\A - Projects\Project Folders\Proj 1601 - 1700\PF 1692\D. RWBC Drawings\FL-15903.13-21.dwg, 2.2

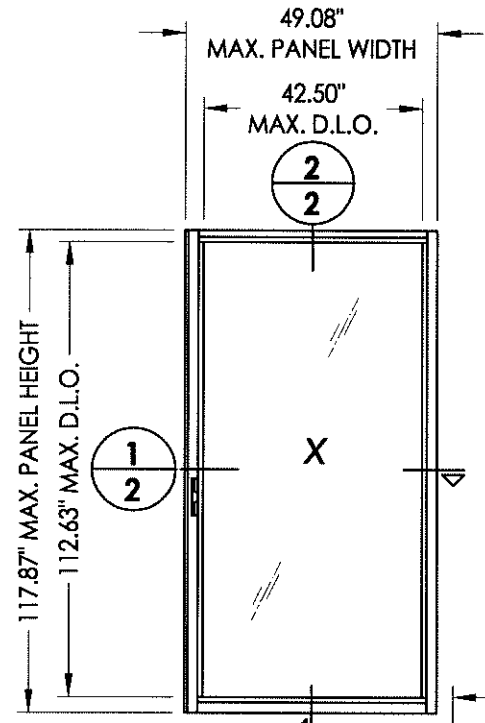

OPERABLE PANEL

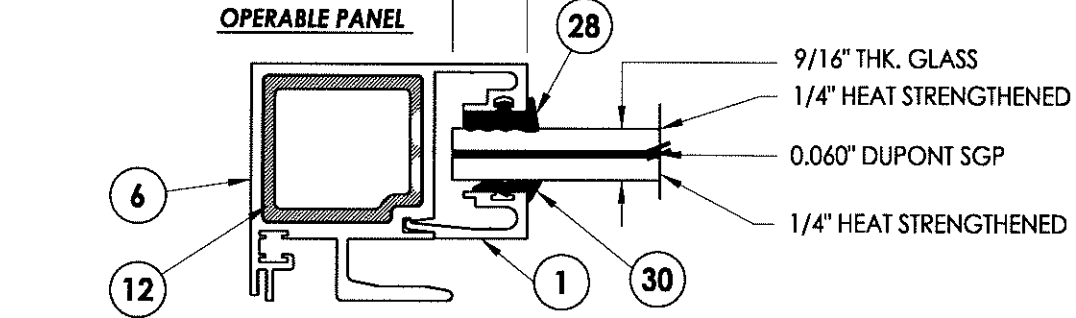

G2 GLAZING DETAIL (DRY GLAZED)
MONOLITHIC
9/16\"/>

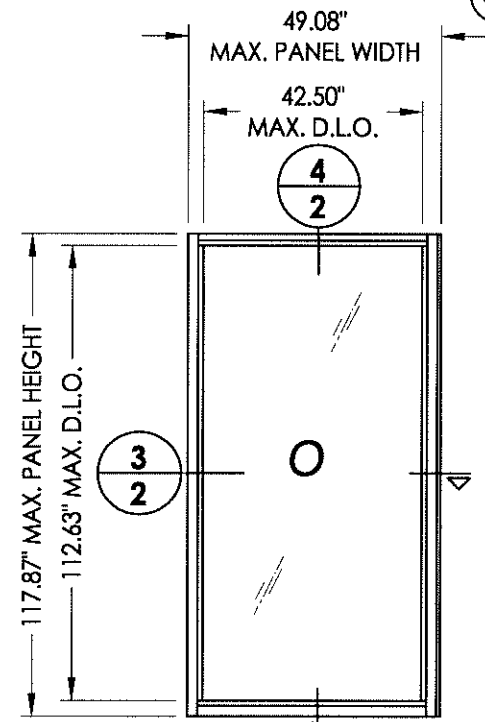

FIXED PANEL

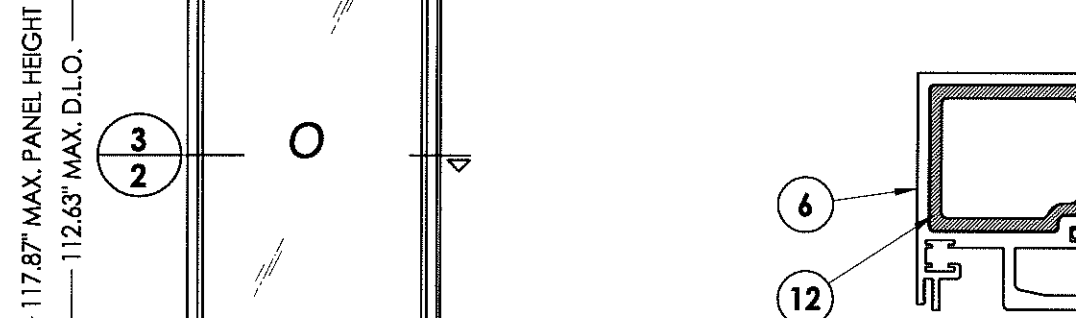

3/2 HORIZONTAL CROSS SECTION

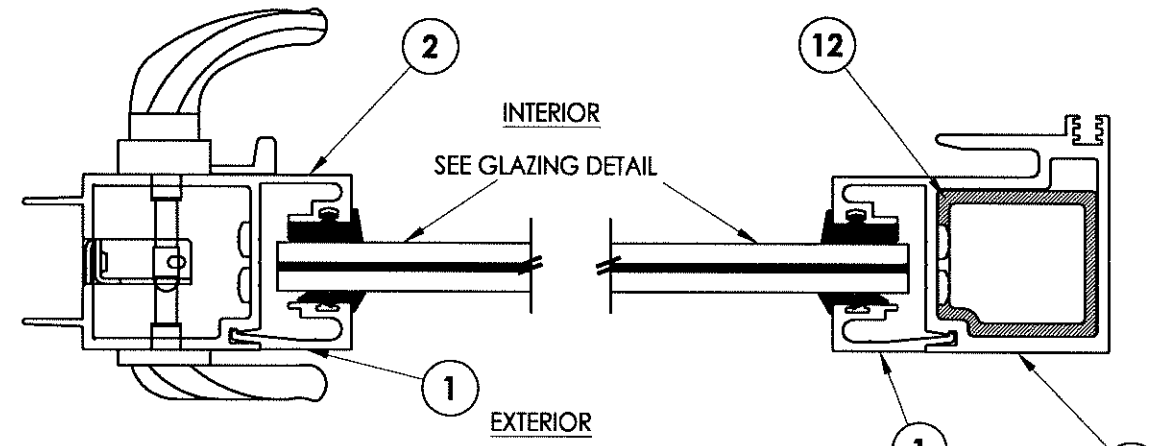

1/2 HORIZONTAL CROSS SECTION

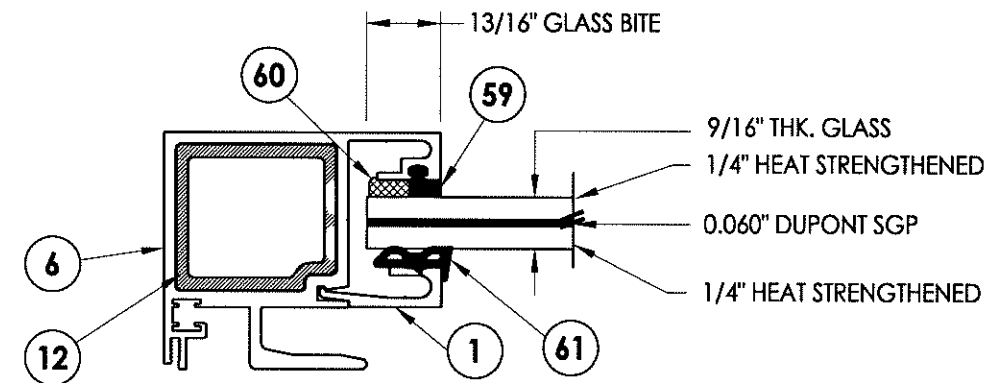

G3 GLAZING DETAIL (WET GLAZED)
MONOLITHIC
9/16\"/>

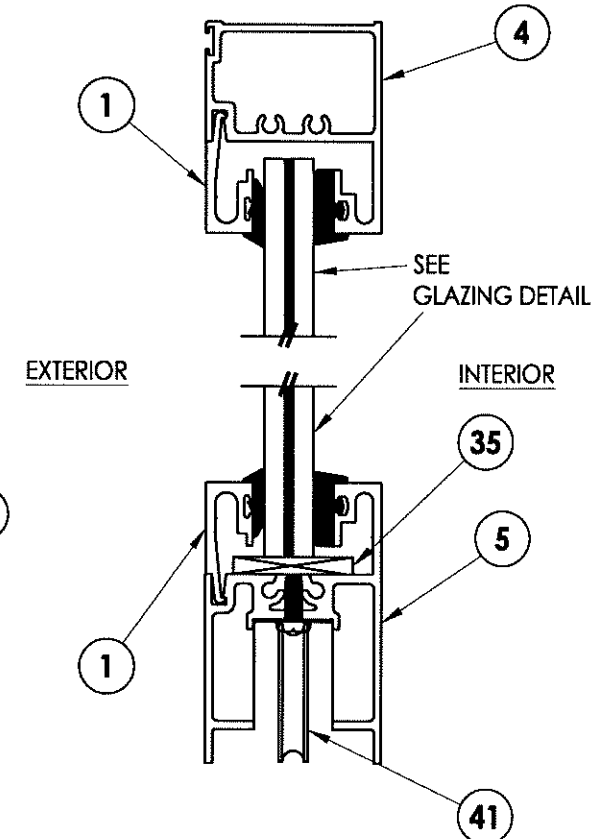

2/2 VERTICAL CROSS SECTION

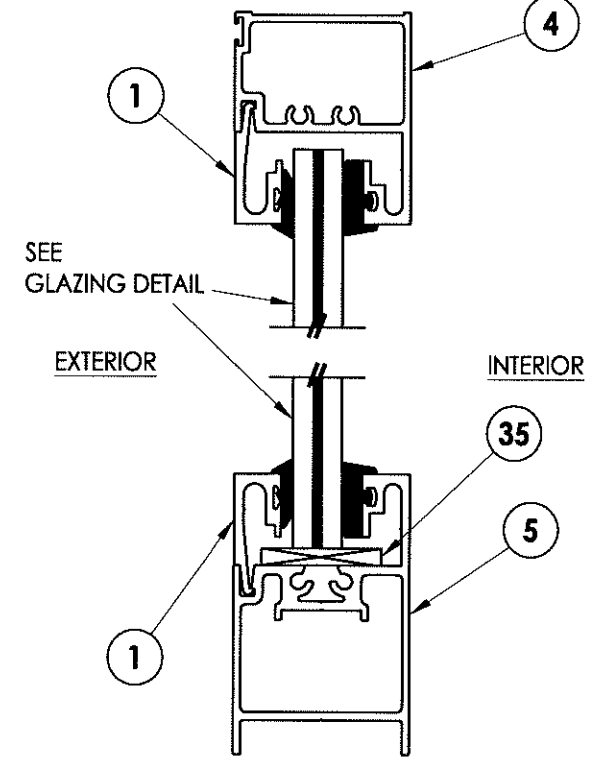

4/2 VERTICAL CROSS SECTION

Documents Prepared By:
RW BUILDING CONSULTANTS, INC.
P.O. Box 230 Valrico FL 33595
Phone No.: 813.659.9197
Florida Board of Professional Engineers
Certificate of Authorization No. 9813
Lyndon F. Schmidt, P.E. No. 43409

PRODUCT: SLIDING GLASS DOOR
PART OR ASSEMBLY: DOOR PANEL SECTIONS

NO.	DATE	BY

DATE: 8/24/12
SCALE: N.T.S.
DWG. BY: JK
CHK. BY: LFS
DRAWING NO.: FL-15903.20
SHEET 2 OF 12

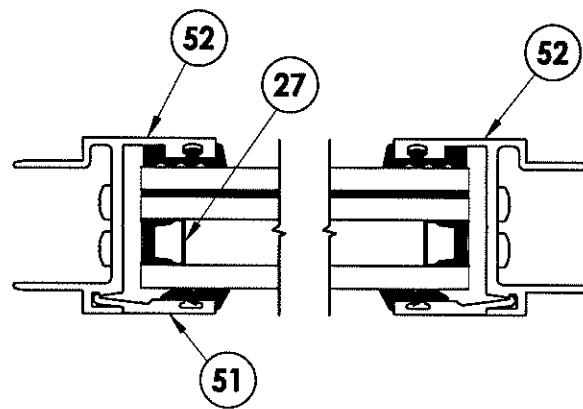
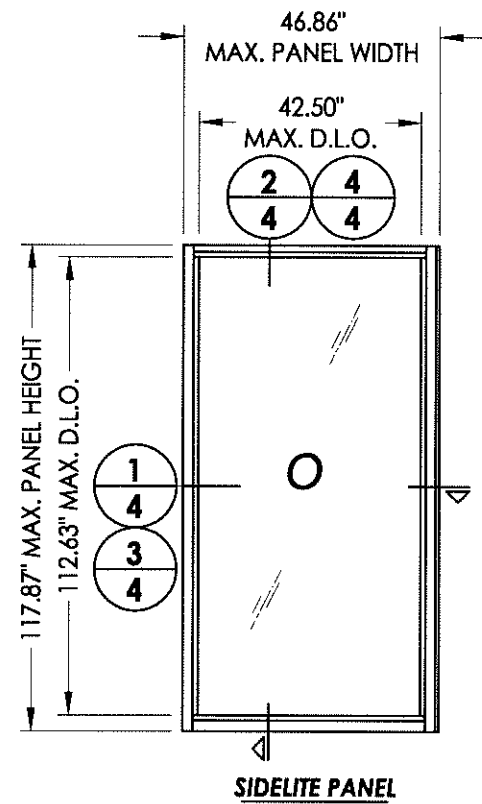

1
4 HORIZONTAL CROSS SECTION

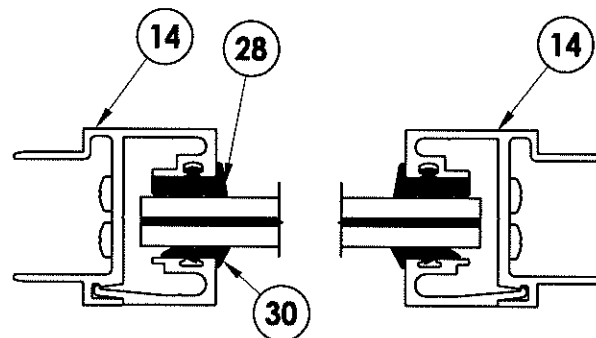

3
4 HORIZONTAL CROSS SECTION

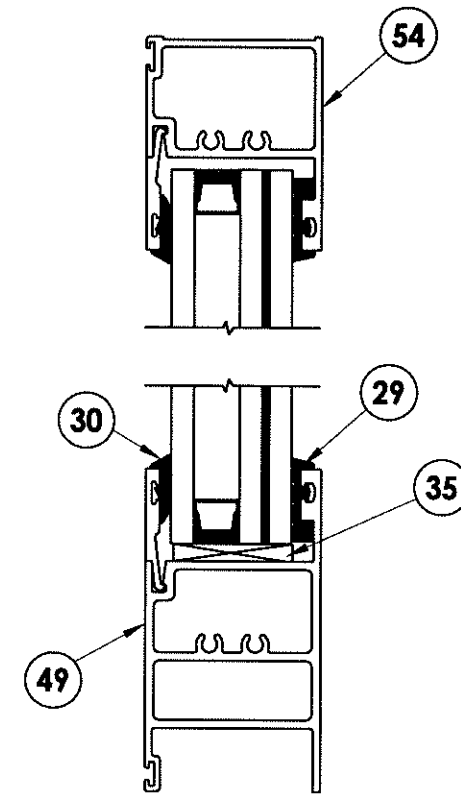

2
4 VERTICAL CROSS SECTION

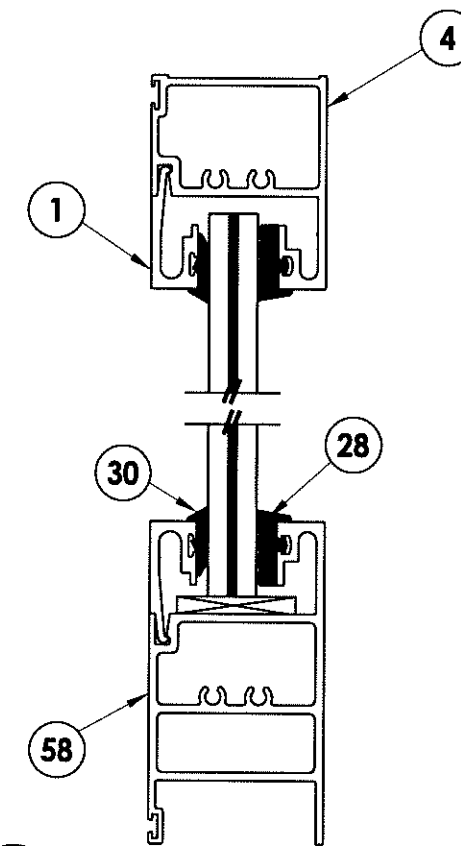

4
4 VERTICAL CROSS SECTION

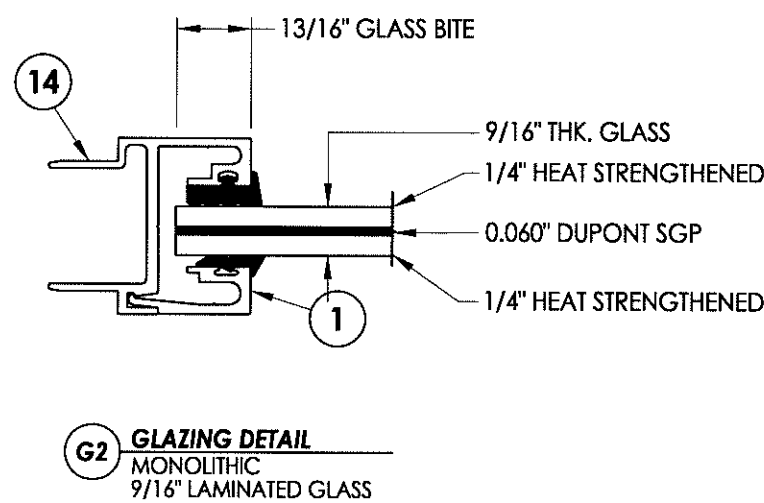
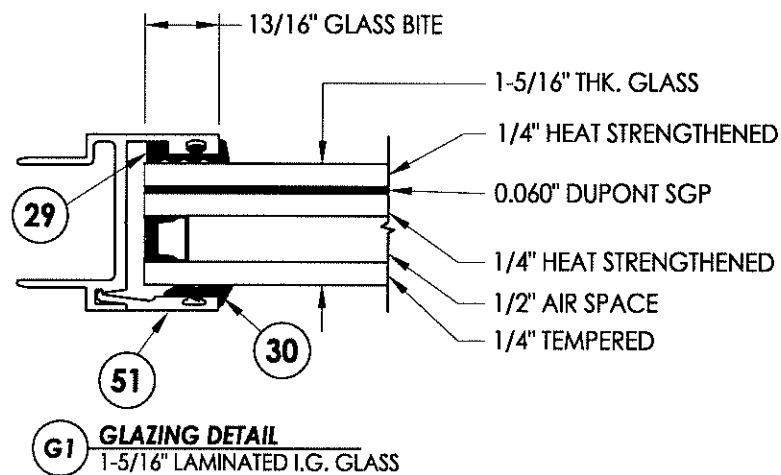

Documents Prepared By:
RW BUILDING CONSULTANTS, INC.
 P.O. Box 230 Valrico FL, 33595
 Phone No.: 813.659.9197
 Florida Board of Professional Engineers
 Certificate Of Authorization No. 9813
 Lyndon F. Schmidt, P.E. No. 43409

PRODUCT:
SLIDING GLASS DOOR

PART OR ASSEMBLY:
SIDELITE PANEL SECTIONS

NO.	DATE	BY

DATE: 8/24/12
 SCALE: N.T.S.
 DWG. BY: JK
 CHK. BY: LFS
 DRAWING NO.: FL-15903.20
 SHEET 4 OF 12

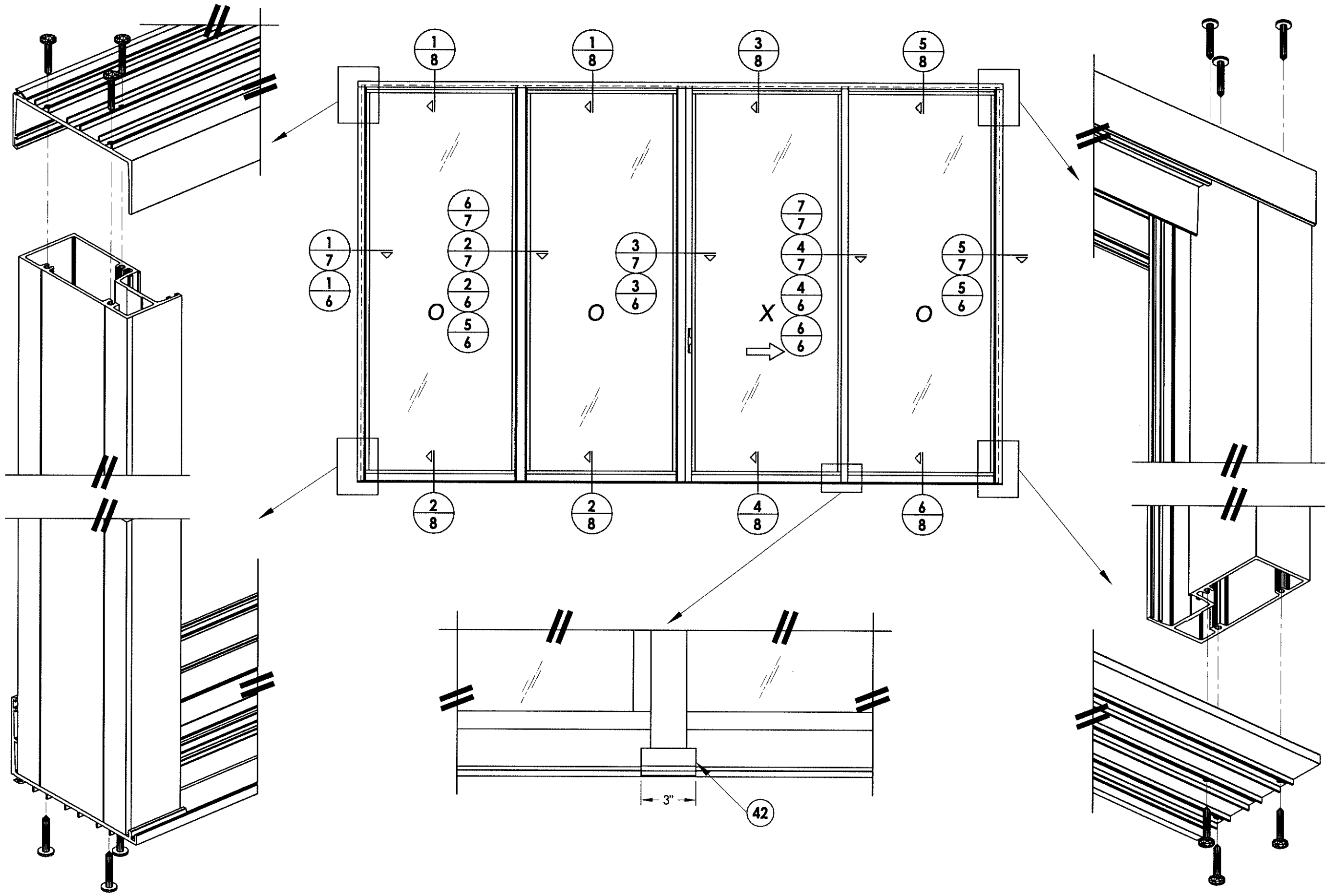

DATE: 8/24/12
 SCALE: N.T.S.
 DWG. BY: JK
 CHK. BY: LFS
 DRAWING NO.: FL-15903.20
 SHEET 5 OF 12

NO.	DATE	REVISIONS	BY

PRODUCT: SLIDING GLASS DOOR
 PART OR ASSEMBLY: CORNER DETAIL

Documents Prepared By:
RW BUILDING CONSULTANTS, INC.
 P.O. Box 230 Vairico FL 33595
 Phone No.: 813.659.9197
 Florida Board of Professional Engineers
 Certificate Of Authorization No. 9813
LFS
 Lyndon F. Schmidt, P.E. No. 43409

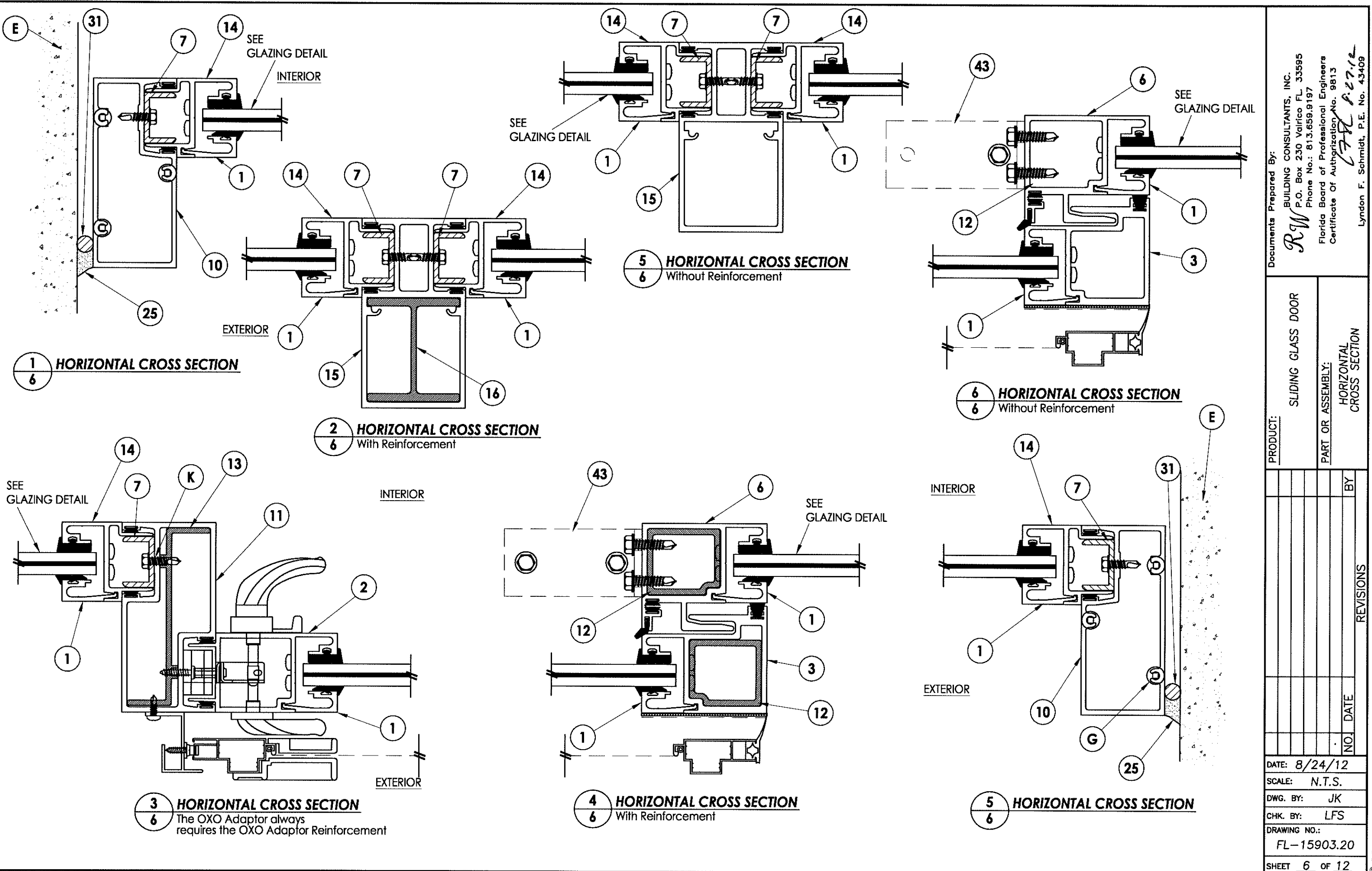

Documents Prepared By:

RW BUILDING CONSULTANTS, INC.
P.O. Box 230 Valrico FL 33595
Phone No.: 813.659.9197
Florida Board of Professional Engineers
Certificate of Authorization No. 9813
LFS 8.27.12
Lyndon F. Schmidt, P.E. No. 43409

PRODUCT: SLIDING GLASS DOOR
PART OR ASSEMBLY: HORIZONTAL CROSS SECTION

NO.	DATE	BY

DATE: 8/24/12
SCALE: N.T.S.
DWG. BY: JK
CHK. BY: LFS
DRAWING NO.: FL-15903.20
SHEET 6 OF 12

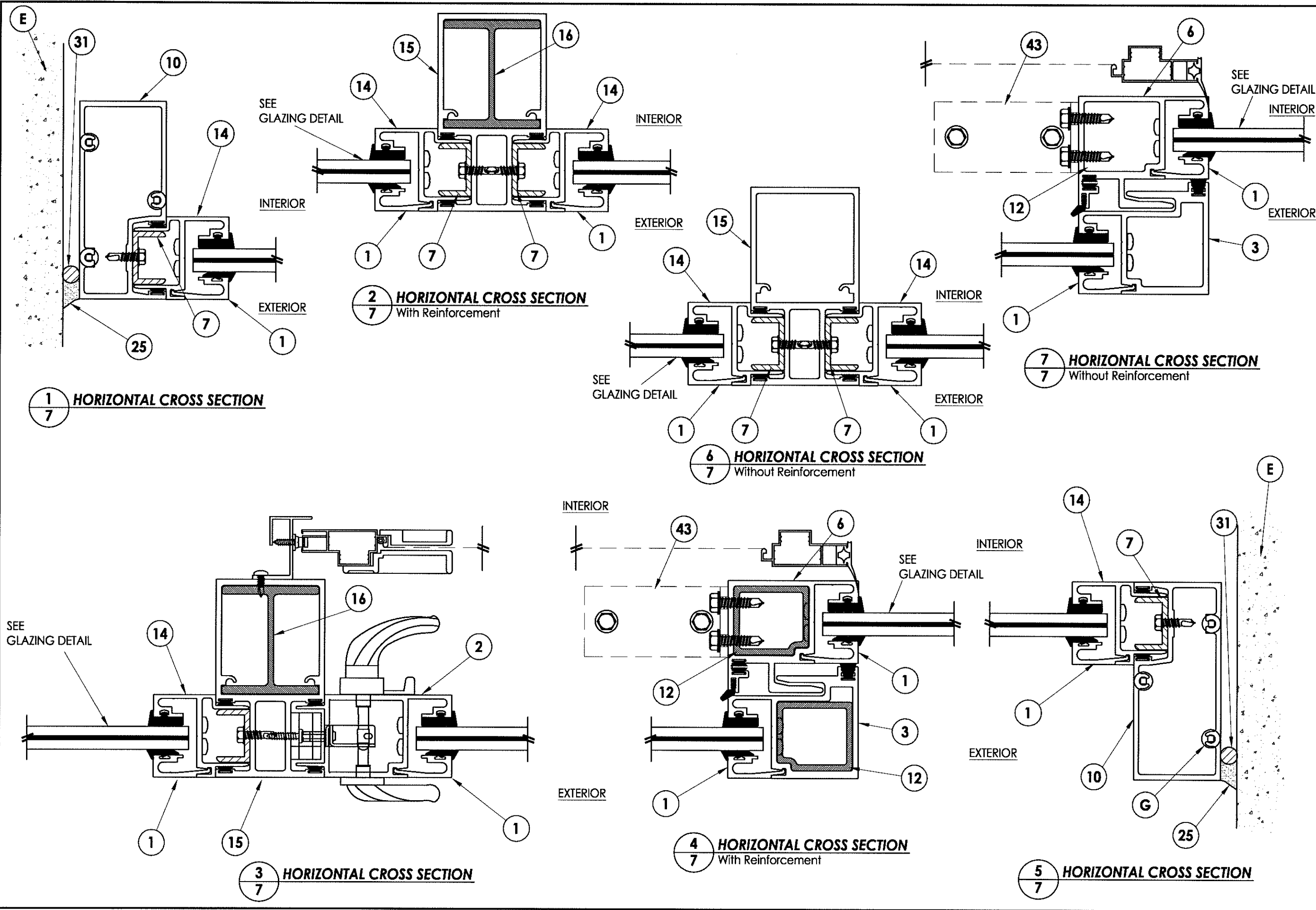

Documents Prepared By: RW BUILDING CONSULTANTS, INC. P.O. Box 230 Valrico FL 33595 Phone No.: 813.659.9197 Florida Board of Professional Engineers Certificate Of Authorization No. 9813 <i>Lyndon F. Schmidt</i> 8/27/12 Lyndon F. Schmidt, P.E. No. 43409	
PRODUCT: SLIDING GLASS DOOR	PART OR ASSEMBLY: HORIZONTAL CROSS SECTION
NO.	DATE
BY	REVISIONS
DATE: 8/24/12	SCALE: N.T.S.
DWG. BY: JK	CHK. BY: LFS
DRAWING NO.: FL-15903.20	
SHEET 7 OF 12	

R:\A - Projects\Project Folders\Proj 1601 - 1700\PF 1692\D. RWBC Drawings\FL-15903.13-21.dwg, 8.2

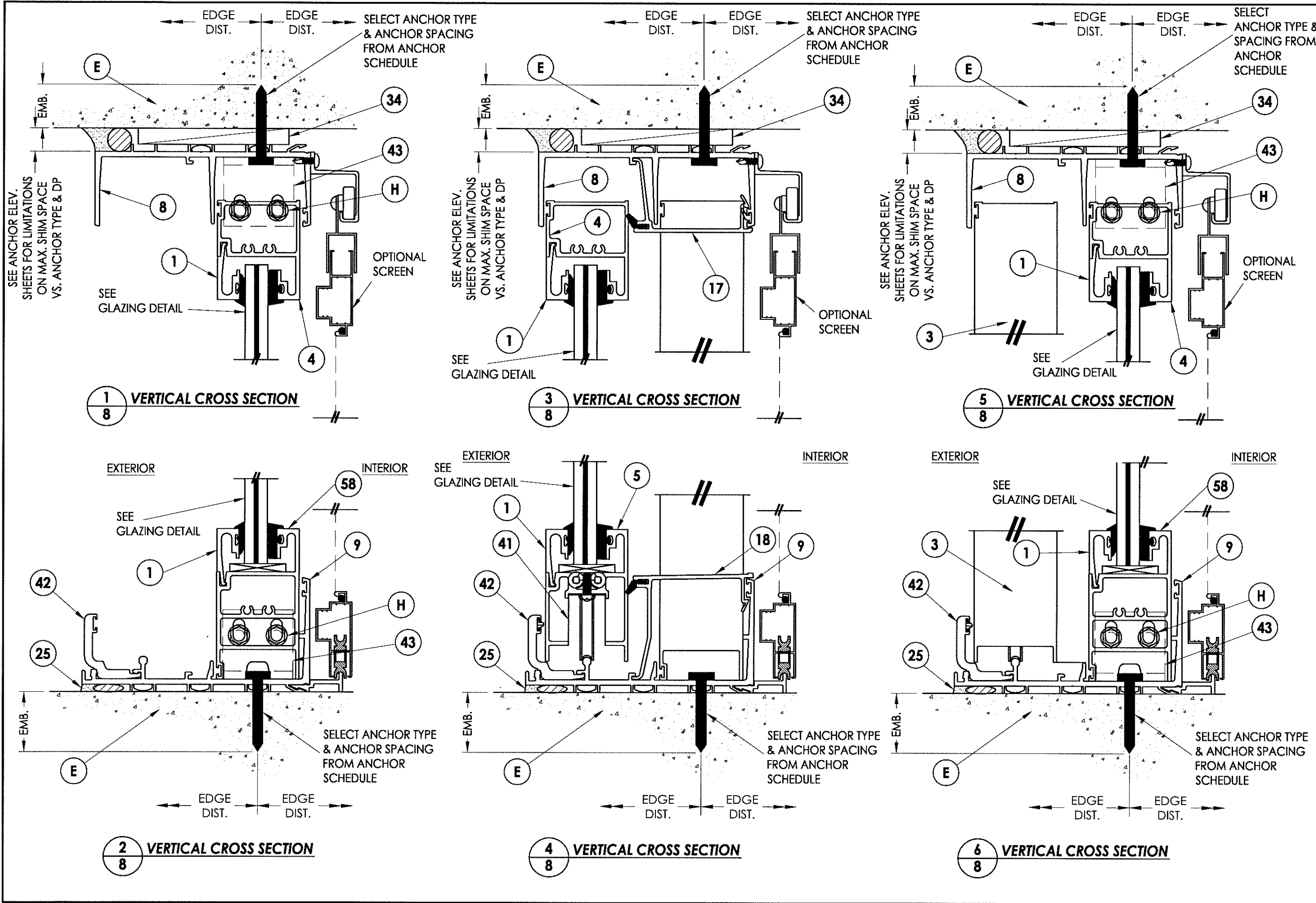

Documents Prepared By: <i>RW</i> BUILDING CONSULTANTS, INC. P.O. Box 230 Valrico FL 33595 Phone No.: 813.659.9197 Florida Board of Professional Engineers Certificate of Authorization No. 9813 <i>17-SEP-2012</i> Lyndon F. Schmidt, P.E. No. 43408	
PRODUCT: SLIDING GLASS DOOR	PART OR ASSEMBLY: VERTICAL CROSS SECTION
NO.	DATE
BY	REVISIONS
DATE: 8/24/12	
SCALE: N.T.S.	
DWG. BY: JK	
CHK. BY: LFS	
DRAWING NO.: FL-15903.20	
SHEET 8 OF 12	

© 2012 R.W. BUILDING CONSULTANTS INC.

R:\A - Projects\Project Folders\Proj 1601 - 1700\PF 1692\D. RWBC Drawings\FL-15903.13-21.dwg, 9.2

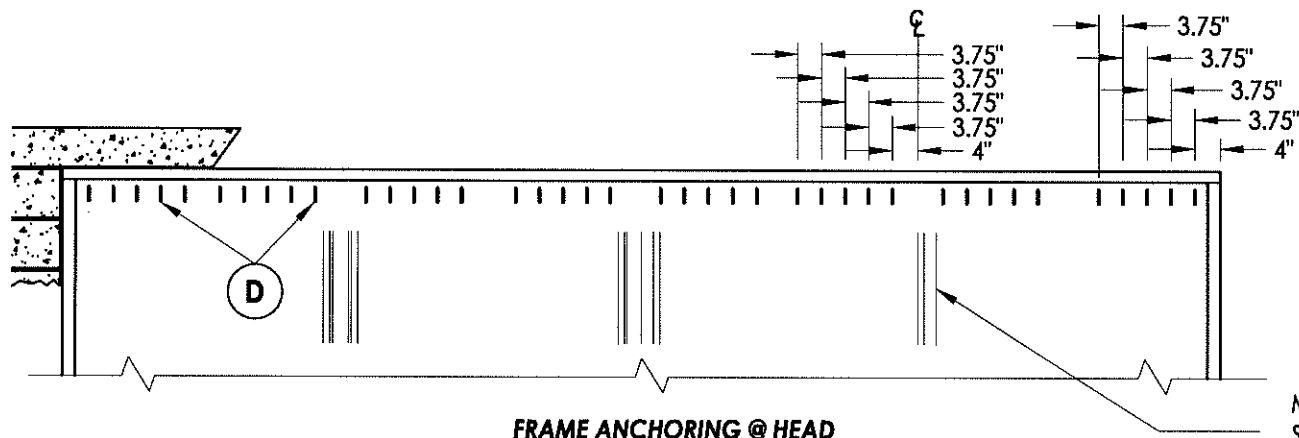

FRAME ANCHORING @ HEAD
 DP <= 70 PSF
 Max. shim space <= .625"

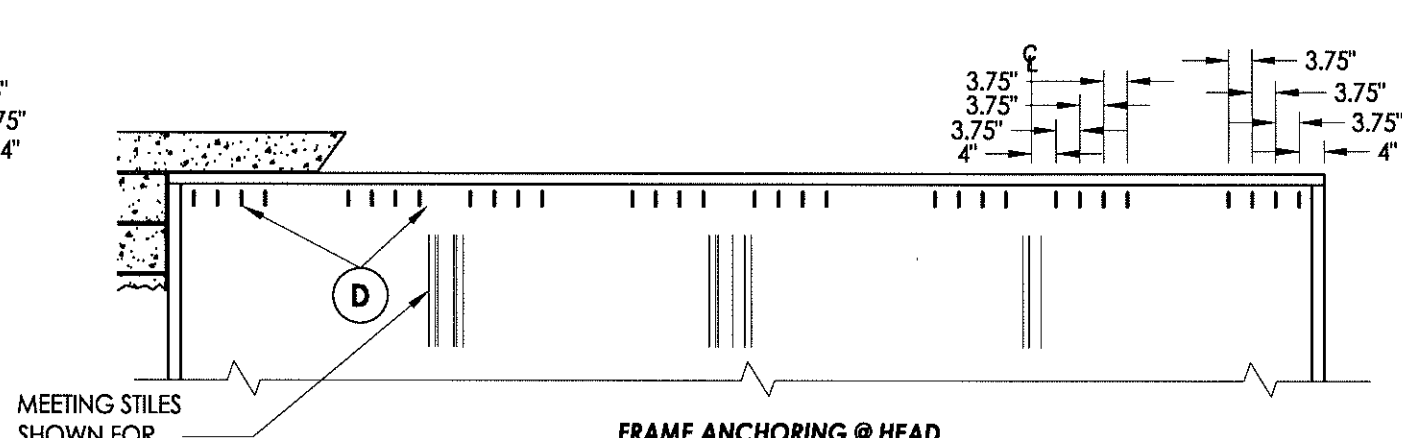

FRAME ANCHORING @ HEAD
 DP <= 100 PSF
 Max. shim space <= .25"

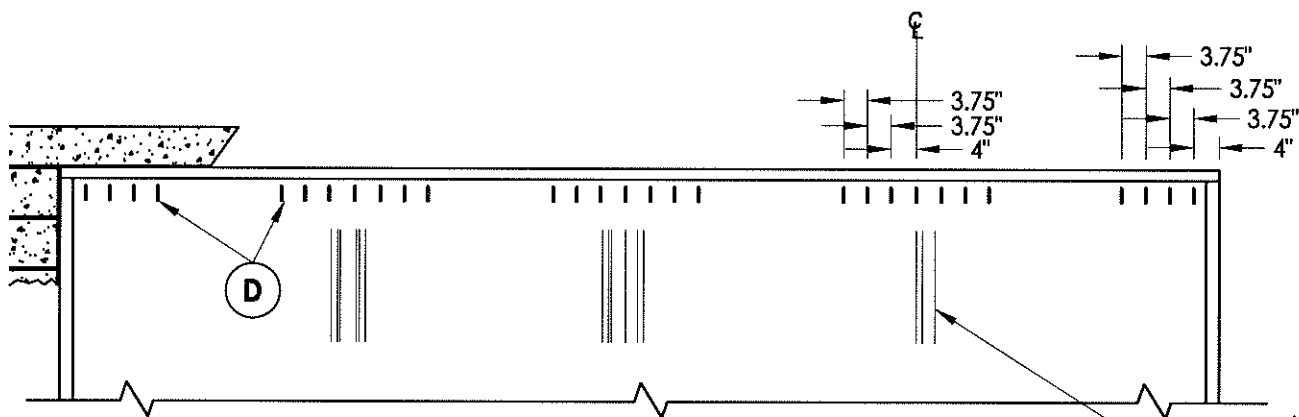

FRAME ANCHORING @ HEAD
 DP <= 68 PSF
 Max. shim space <= .41"

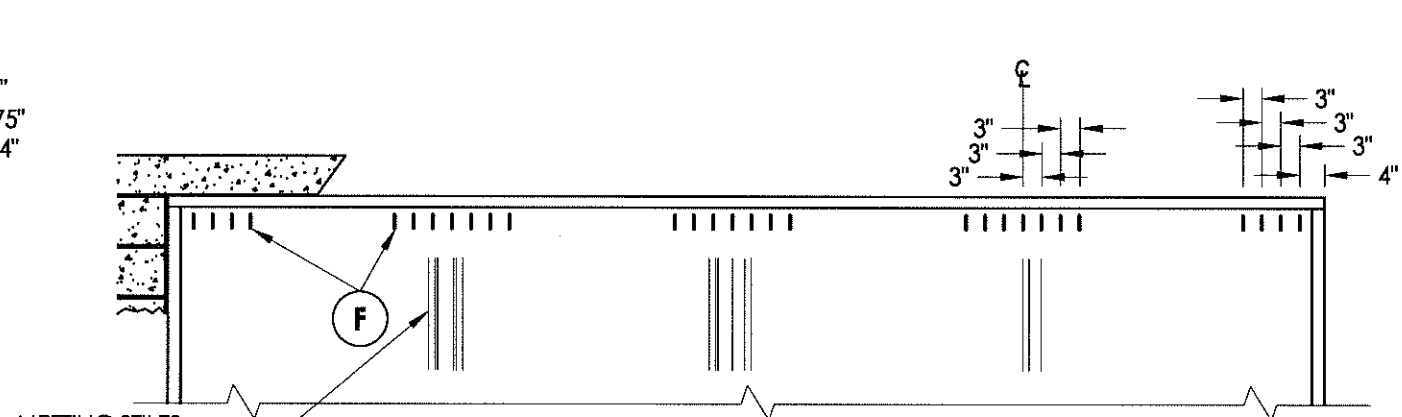

FRAME ANCHORING @ HEAD
 DP <= 100 PSF
 Max. shim space <= .625"

SUBSTRATE	ANCHOR SCHEDULE	
CONCRETE	D	5/16" x 2-3/4" ITW (XL) HWH concrete screw with 1.75" Min. embedment, 4" minimum edge distance and 3.75" minimum clearance to adjacent concrete anchors. Concrete is 2,899 PSI minimum conforming to ACI 301.
	F	3/8" diameter x 2-1/4" ITW Dyna-Bolt sleeve anchor with 1.5" minimum embedment, 2.5" minimum edge distance and 3.0" minimum clearance to adjacent concrete screws. Concrete is 2,000 PSI minimum conforming to ACI 301.

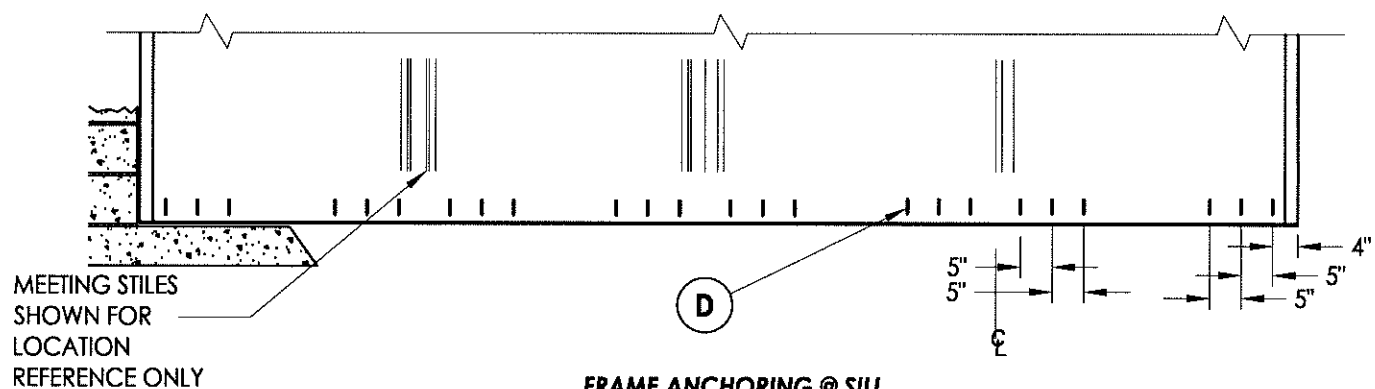

FRAME ANCHORING @ SILL
 DP <= 100 PSF
 Max. shim space <= 0.17"

Documents Prepared By:
RW BUILDING CONSULTANTS, INC.
 P.O. Box 230 Valrico FL 33595
 Phone No.: 813.659.9197
 Florida Board of Professional Engineers
 Certificate of Authorization No. 9813
 L7-R-27-12
 Lyndon F. Schmidt, P.E. No. 43409

PRODUCT: SLIDING GLASS DOOR
 PART OR ASSEMBLY: ANCHORING CONCRETE SUBSTRATE

NO.	DATE	BY	REVISIONS

DATE: 8/24/12
 SCALE: N.T.S.
 DWG. BY: JK
 CHK. BY: LFS
 DRAWING NO.: FL-15903.20
 SHEET 9 OF 12

© 2012 R.W. BUILDING CONSULTANTS INC.

SUBSTRATE		ANCHOR SCHEDULE
CONCRETE	(D)	5/16" x 2-3/4" ITW (XL) HWH concrete screw with 1.75" Min. embedment, 4" minimum edge distance and 3.75" minimum clearance to adjacent concrete anchors. Concrete is 2,899 PSI minimum conforming to ACI 301.
STEEL	(H)	1/4"-20 HWH Hilti KWIK PRO self-drilling screws. Steel with 0.125" minimum wall thickness conforming to ASTM A500 Grade B, Fy = 46,000 PSI & Fu = 58,000 PSI or ASTM A653, Fy = 33,000 PSI, Fu = 45,000 PSI. Minimum embedment of 3 threads through steel substrate.

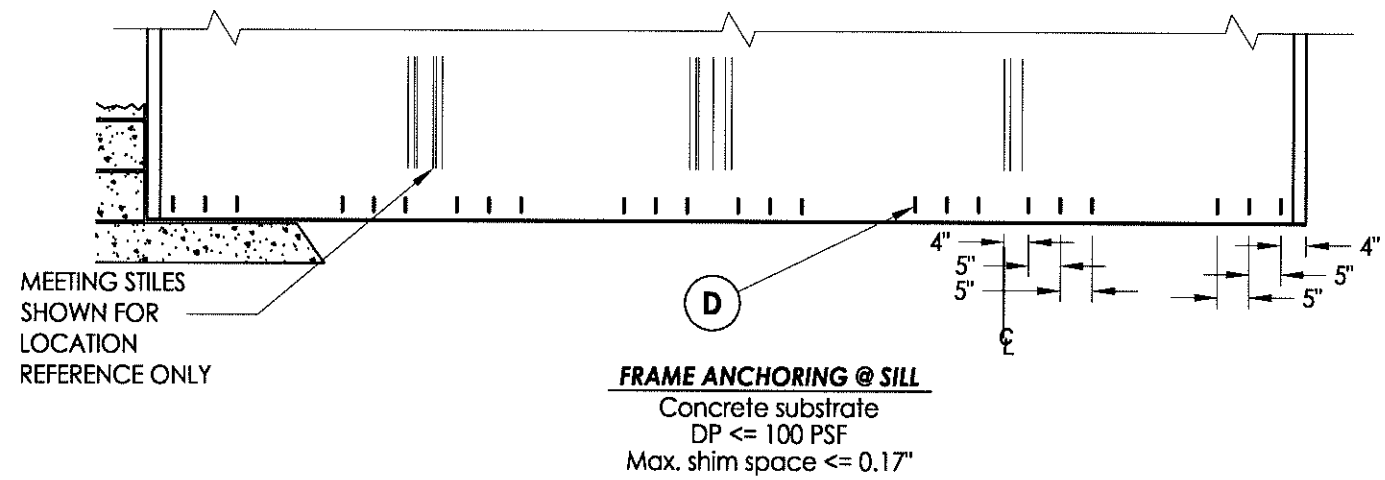
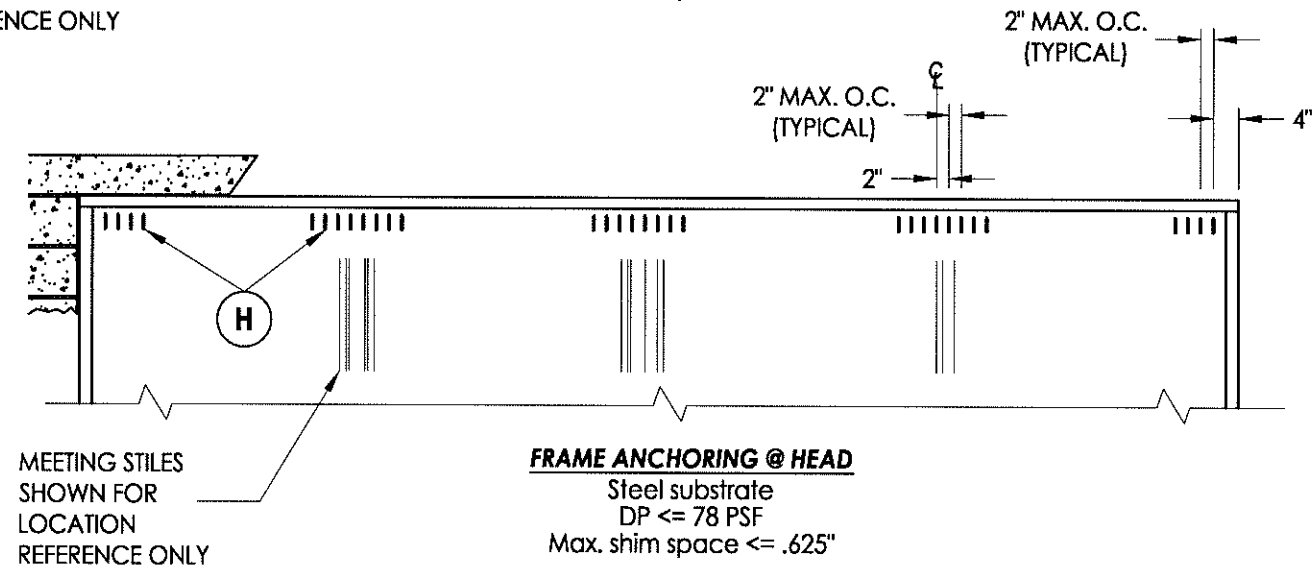
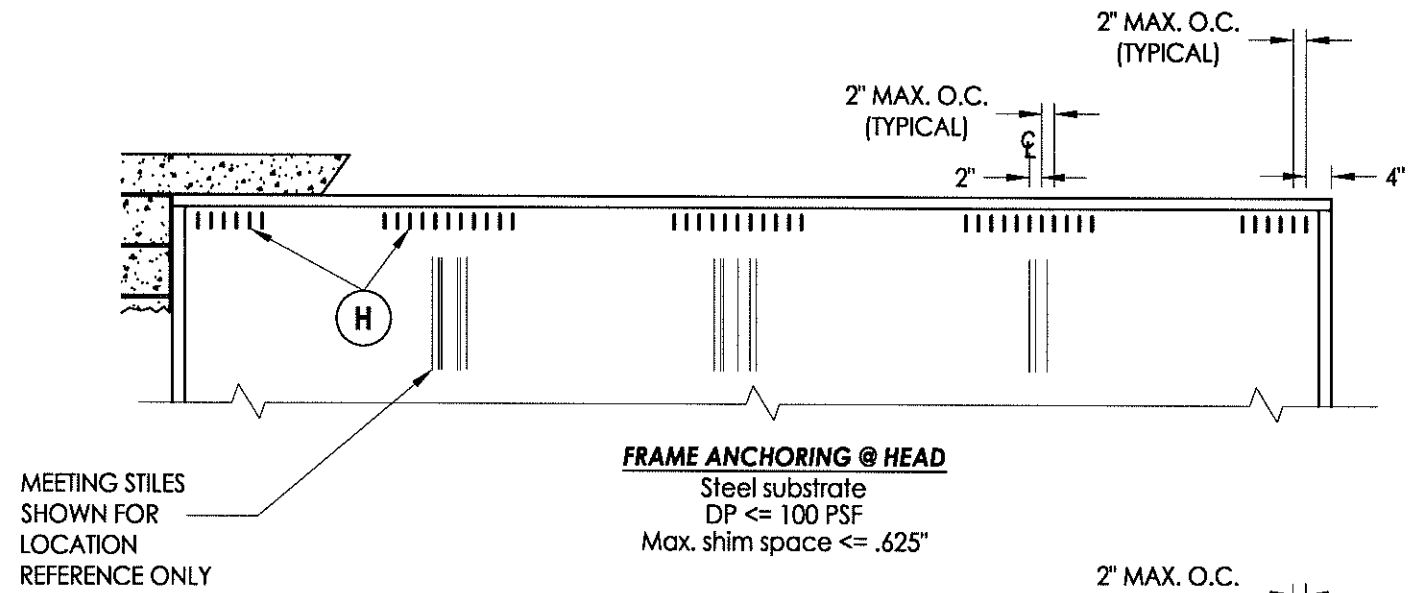

Documents Prepared By:

RW BUILDING CONSULTANTS, INC.
P.O. Box 230 Valrico FL 33595
Phone No.: 813.659.9197
Florida Board of Professional Engineers
Certificate of Authorization No. 9813
Lyndon F. Schmidt, P.E. No. 43409

PRODUCT: SLIDING GLASS DOOR

PART OR ASSEMBLY: ANCHORING STEEL SUBSTRATE

NO.	DATE	BY	REVISIONS

DATE: 8/24/12

SCALE: N.T.S.

DWG. BY: JK

CHK. BY: LFS

DRAWING NO.:

FL-15903.20

SHEET 10 OF 12

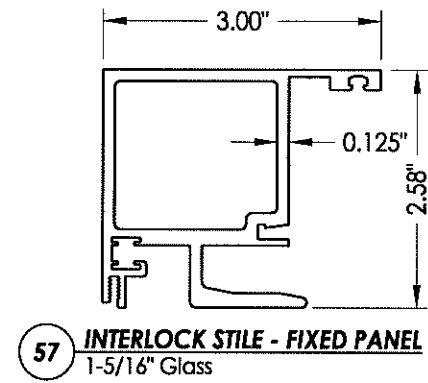
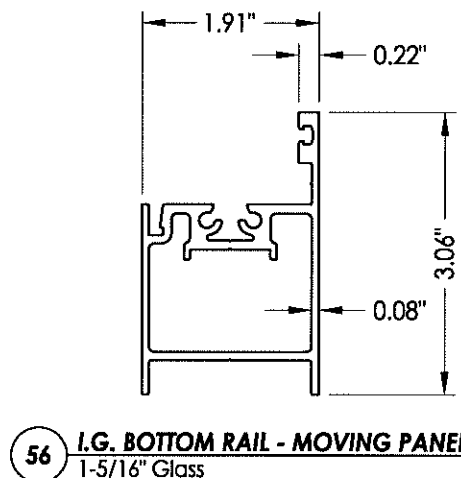
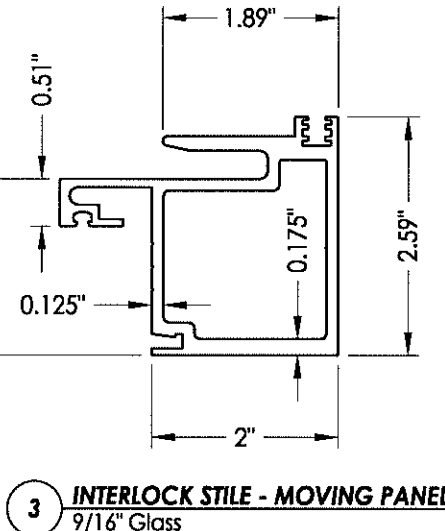
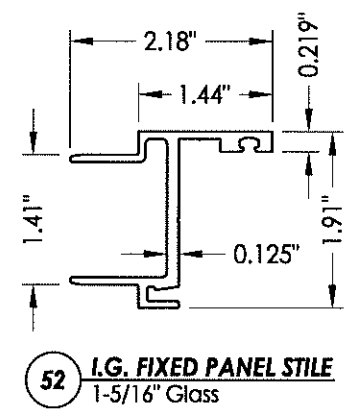
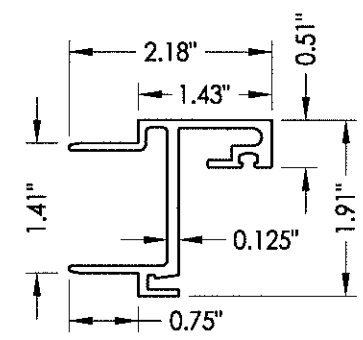
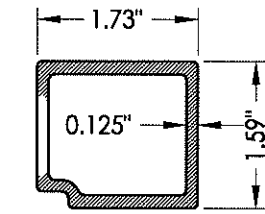
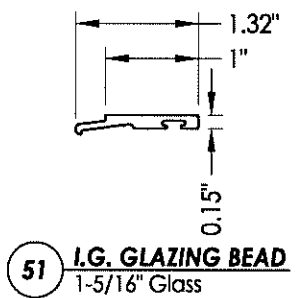
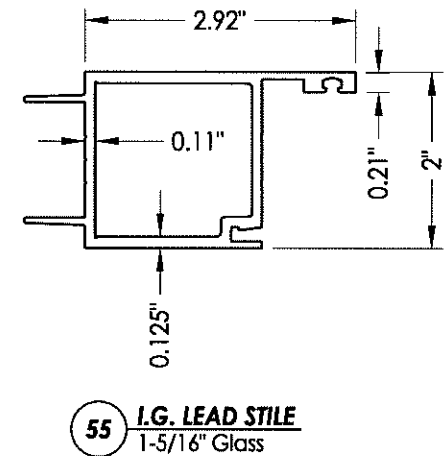
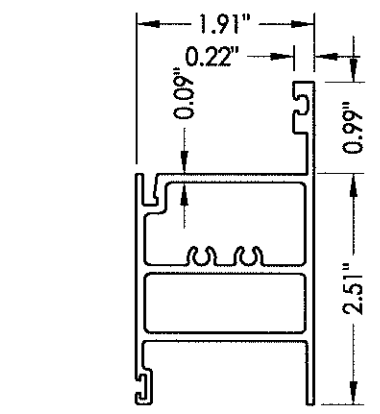
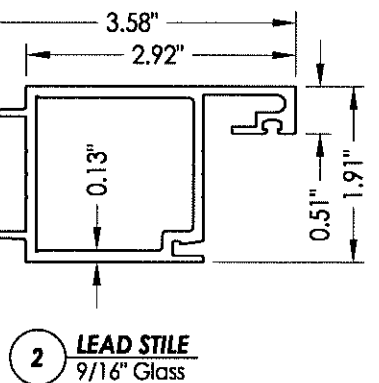
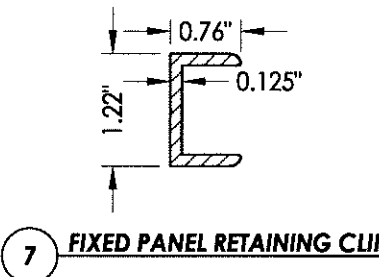
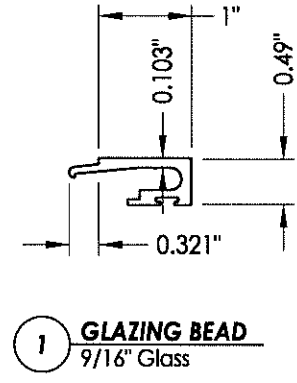
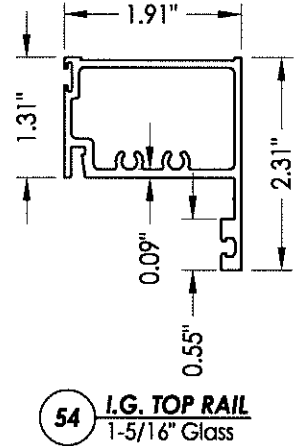
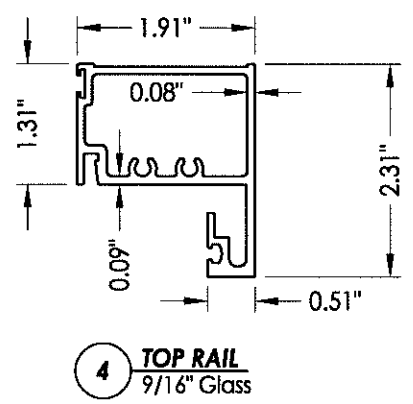
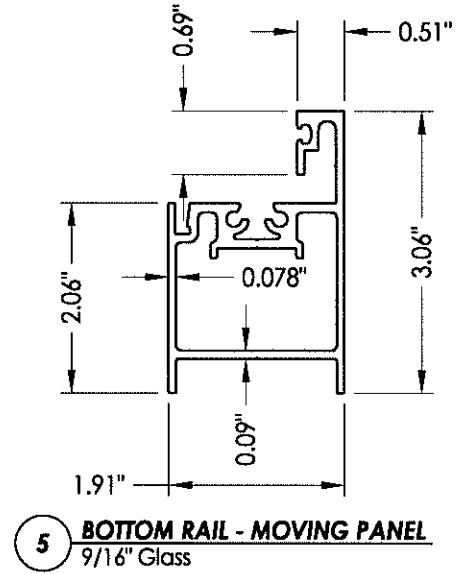
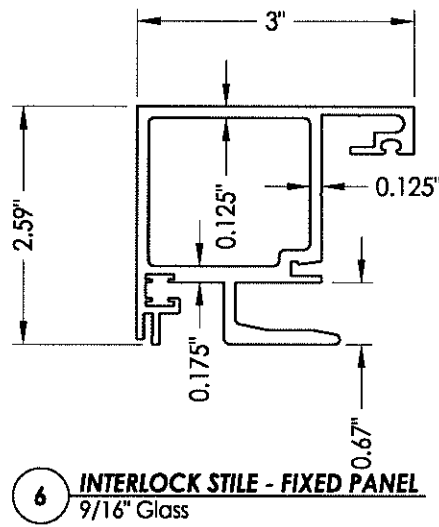

Documents Prepared By:
RW BUILDING CONSULTANTS, INC.
 P.O. Box 230 Valrico FL 33595
 Phone No.: 813.659.9197
 Florida Board of Professional Engineers
 Certificate Of Authorization No. 9813
 Lyndon F. Schmidt, P.E. No. 43408

PRODUCT: SLIDING GLASS DOOR
 PART OR ASSEMBLY: COMPONENTS

NO.	DATE	BY

DATE: 02/26/08
 SCALE: N.T.S.
 DWG. BY: JK
 CHK. BY: LFS
 DRAWING NO.: FL-15903.20
 SHEET 11 OF 12

R:\A - Projects\Project Folders\Proj 1601 - 1700\PF 1692\D. RWBC Drawings\FL-15903.13-21.dwg, 12.2

BILL OF MATERIALS		
ITEM	DESCRIPTION	MATERIAL
D	5/16" X 2-3/4" ITW HWH CONCRETE SCREW	STEEL
E	MASONRY - 3,192 PSI MIN. CONCRETE CONFORMING TO ACI 301 OR HOLLOW BLOCK CONFORMING TO ASTM C90	CONCRETE
F	3/8" X 2-1/2" DYNA BOLT SLEEVE ANCHOR	STL. STEEL
G	#10 X 1-1/2" SQ-PH ASSEMBLY SCREW	STL. STEEL
H	1/4"-20 HWH HILTI KWIK PRO SELF-DRILLING SCREW (WITH KWIK-COTE COATING)	STL. STEEL
K	#10 X 3/4" HH-SELF TAP SCREW	STL. STEEL
1	GLAZING BEAD 6063-T6 (9/16")	ALUM
2	LEAD STYLE 6063-T6 (9/16")	ALUM
3	INTERLOCK STILE - MOVING PANEL 6005-T5 (9/16")	ALUM
4	TOP RAIL 6063-T6 (9/16")	ALUM
5	BOTTOM RAIL - MOVING PANEL 6063-T6 (9/16")	ALUM
6	INTERLOCK STILE - FIXED PANEL 6005-T6 (9/16")	ALUM
7	FIXED PANEL RETAINING CLIP 6063-T6	ALUM
8	FRAME HEAD 6063-T6	ALUM
9	FRAME SILL 6063-T6	ALUM
10	FRAME JAMB 6063-T6	ALUM
11	OXO ADAPTOR 6005-T5	ALUM
12	REINFORCEMENT 6005-T5	ALUM
13	OXO ADAPTOR REINFORCEMENT 6005-T5	ALUM
14	FIXED PANEL STILE 6063-T6 (9/16")	ALUM
15	XX ADAPTOR 6005-T5	ALUM
16	XX ADAPTOR REINFORCEMENT 6005-T5	ALUM
17	FRAME HEAD POCKET COVER 6063-T6	ALUM
18	FRAME SILL POCKET COVER 6063-T6	ALUM
25	WEATHERSEAL SEALANT (WS001) DOW 795	SILICONE
27	GLAZING SPACER	-
28	GASKET, EPDM CLOSED CELL FOAM (9/16" STRUCTURAL GLAZING)	EPDM
29	GASKET, EPDM CLOSED CELL FOAM (1-5/16" GLAZING)	EPDM
30	WEDGE 70±5 EPDM (1-5/16" GLAZING)	EPDM
31	BACKER ROD - CLOSED CELL EXTRUDED FOAM	POLYETHYLENE
34	SHIM	-
35	SETTING/EDGE BLOCK	PLASTIC
41	ROLLER ASSM.	STL. STEEL
42	REACTION CLIP 6005-T5	ALUM
43	TOE ANCHOR 6005-T5	STEEL
49	BOTTOM RAIL - FIXED PANEL 6063-T6 (1-5/16")	ALUM
51	I.G. GLAZING BEAD 6063-T6 (1-5/16")	ALUM
52	I.G. FIXED PANEL STILE 6063-T6 (1-5/16")	ALUM
53	I.G. INTERLOCK STILE - MOVING PANEL 6063-T6 (1-5/16")	ALUM
54	I.G. TOP RAIL 6063-T6 (1-5/16")	ALUM
55	I.G. LEAD STYLE 6063-T6 (1-5/16")	ALUM
56	I.G. BOTTOM RAIL - MOVING PANEL 6063-T6 (1-5/16")	ALUM
57	INTERLOCK STILE - FIXED PANEL (1-5/16")	ALUM
58	BOTTOM RAIL - FIXED PANEL 6063-T6 (9/16")	ALUM
59	CAULK STOP, EPDM CLOSED CELL FOAM (9/16" STRUCTURAL GLAZING)	EPDM
60	STRUCTURAL SILICONE DOW 995	SILICONE
61	WEDGE, 70±5 EPDM (9/16" GLAZING)	EPDM

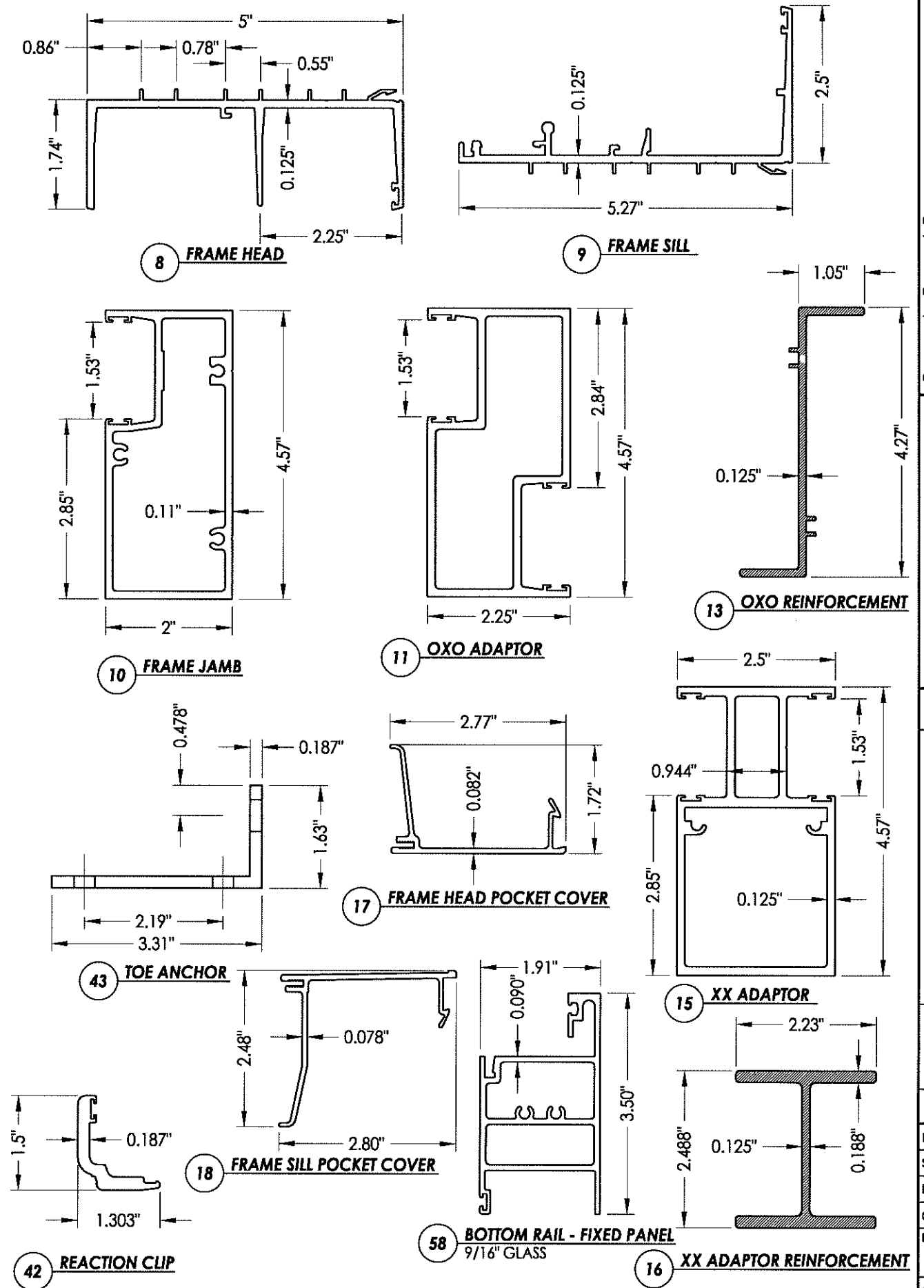

Documents Prepared By: **RW BUILDING CONSULTANTS, INC.**
P.O. Box 230 Valrico FL 33595
Phone No.: 813.659.9197
Florida Board of Professional Engineers
Certificate of Authorization No. 9813
Lyndon F. Schmidt, P.E. No. 43409

PRODUCT: SLIDING GLASS DOOR

PART OR ASSEMBLY: BILL OF MATERIALS & COMPONENTS

NO.	DATE	BY

REVISIONS

DATE: 02/26/08
SCALE: N.T.S.
DWG. BY: JK
CHK. BY: LFS
DRAWING NO.: FL-15903.20
SHEET 12 OF 12

© 2012 R.W. BUILDING CONSULTANTS INC.